

70510-01000 Underbench Workstation

Hydropneumatic · Bottom-up workstation for Avdel speed fasteners

A cost-effective workstation requiring minimum space and set-up. The base can be bolted to a workbench in seconds to provide a compact bottom-up fastening system.

Foot pedal control leaves operator hands free to position the workpiece, reducing assembly time and operator fatigue. The hydraulic riveting unit provides a smooth riveting operation, ideal for sensitive components.

Features

- Bottom-up fastening
- Mandrel head provides jig point for components
- Foot pedal control, leaving both hands free to position the workpiece
- Easy alignment and precision assembly of small components
- Interlocked safety guard: tool cannot be operated unless guard is in position
- Pneumatic lines are concealed within base: the base can simply be bolted to a workbench
- Long-life detached intensifier can be floor or bench mounted to maximise workspace



Technical Data

Pull Force	: 3,000 N at 5.5 bar
Stroke	: 30 mm (max.)
With 3 buffer stops as standard	: 21 mm
Cycle Time	: 1.0 sec (approx.)
Noise Level	: < 70 dB
Air Pressure Supply	: 4.5 - 5.5 bar
Air Consumption	: 2.6 l free air / sets at 5.0 bar
Intensifier Ratio	: 32 : 1

Placing Capability

The 70510 placing tool can place the full range of Speed Fastening® fasteners from diameter 2.4 mm to 6.4 mm.

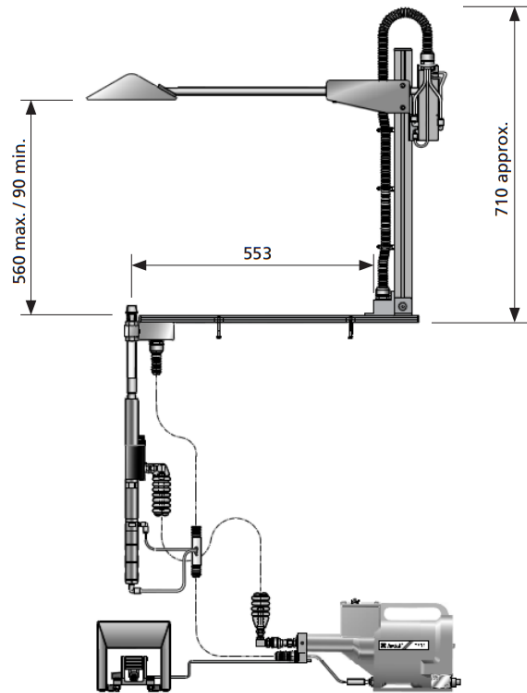

*Nose equipment has to ordered separately.
For accessories options, contact Gripwell
Sales for assistance*



We are proud to be Avdel's authorized distributor of over 30 years